

AIM-D100-CA series DC Insulation Monitor

User Manual V1.0

Declaration

Please read this instruction carefully before using this product. All pictures, logos and symbols involved are owned by Acrel Co., Ltd. All or part of the content shall not be reproduced publicly without written authorization by non-company personnel.

Please read the instructions and precautions in this operation manual carefully before using this series of products. Acrel will not be responsible for personal injury or economic loss caused by ignoring the instructions in this operation manual.

The equipment is professional electrical equipment, any related operation, need to be carried out by special electrical technicians. Acrel is not responsible for personal injury or financial loss resulting from the error of non-professional personnel.

The contents of this description will be updated and amended constantly, and it is inevitable that there will be a slight discrepancy between the physical product and the description in the product function upgrading. Please refer to the physical product purchased and obtain the latest version of the description through www.acrel-electric.com or sales channels.

Modified Records

No.	Date	Version	Description
1	2023.10.20	V1.0	First version
Notes:			

Contents

1 Introduction	1
2 Model Description	1
3 Functional Characteristics	1
4 Technical Parameters	2
5 Installation and Connection	2
5.1 Shape and Size	2
5.2 Installation	3
5.3 Wiring	4
5.4 Wiring Diagram	5
5.5 Attention	5
6 Programming and Usage	6
6.1 Panel Description	6
6.2 LED Indicator Instructions	6
6.3 DIP Switch Description	7
7 Communication Instruction	7
7.1 Communication Protocol	7
7.2 Function Code Introduction	8
7.3 Register Address Table	9
7.4 Register Operation Description	10
7.5 Message Example	11
8 Application	12

AIM-D100-CA series DC Insulation Monitor

1 Introduction



With the development of industry, many electrical equipment and factory equipment are powered by DC systems, and the positive and negative poles of the DC system are not grounded. For ungrounded (IT) power distribution systems, insulation resistance should be monitored to ensure the safe operation of the power supply system.

AIM-D100-CA series DC insulation monitor can be applied in DC system of 0~1000V, used for on-line monitoring of DC ungrounded system positive and negative pole to ground insulation resistance, when insulation resistance is lower than the set value, it will send out warning or alarm signal.

The product is mainly designed for DC 0~1000V range of electric vehicle charging device insulation monitoring, but also can be applied in energy storage DC, substation DC screen, UPS power supply system, photovoltaic DC system and other DC power grid DC system.

2 Model Description

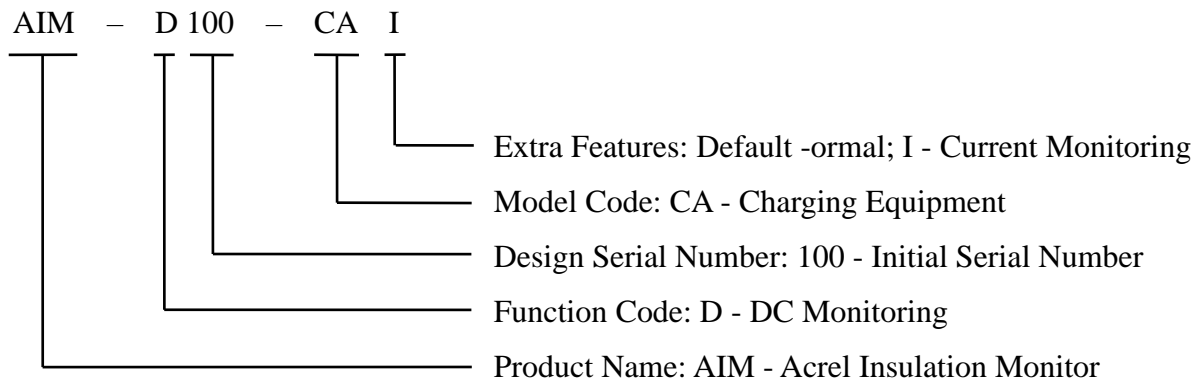

3 Functional Characteristics

- Resistance monitoring. The product can monitor the insulation resistance of the positive and negative poles of the DC system to the ground. When the insulation resistance is lower than the set warning and alarm values, it can send out warning and alarm signals.
- Voltage monitoring. The product can monitor the voltage between the positive and negative poles of the DC system and the voltage between the positive and negative poles with respect to ground. The measurement range is 0~1000V.
- Current monitoring function. The product can monitor the current of DC system, only the AIM-D100-CAI model has this function.
- LED indication. The product panel has operation, communication, and fault LED indicators to

display product status.

- Communication networking function. The product has RS485 interface and adopts Modbus-RTU protocol for data exchange.
- Metal casing. The product adopts a metal shell and can be wall-mounted or installed using accessory rails.
- Plug-in terminals. The product adopts plug-in terminal wiring, which is convenient for wiring and installation.

4 Technical Parameters

Technical Parameter		Technical Specifications
Auxiliary power		DC 9~36V
Maximum power consumption		≤6W
Voltage monitoring	Voltage range	DC 0~1000V
	Accuracy	0.5 grade
Current monitoring	Current monitoring	Connect with current shunt base on rated current; CAI models only
	Accuracy	5%
Insulation monitoring	Insulation resistance range	1kΩ~10MΩ
	Warning and alarm range	10kΩ~10MΩ
	Accuracy	1~10kΩ: ±1k; 10k~500k: ≤3%
	System leakage capacitance	≤5μF
	Insulation monitoring speed	500ms/cycle; 1000ms/cycle
Alarm method		LED indicator
Communication		RS485 interface, Modbus-RTU protocol
Installation		Wall-mounted installation or DIN-rail installation (plastic stent included)
Protection level		IP30
Environment	Operating temperature	-40~+75°C
	Storage temperature	-40~+125°C
	Relative humidity	<95%, without condensation
	Altitude	<2000m

5 Installation and Connection

5.1 Shape and Size

The overall dimensions of the AIM-D100-CA DC Insulation Monitor are shown in the figure below.
(Unit: mm)

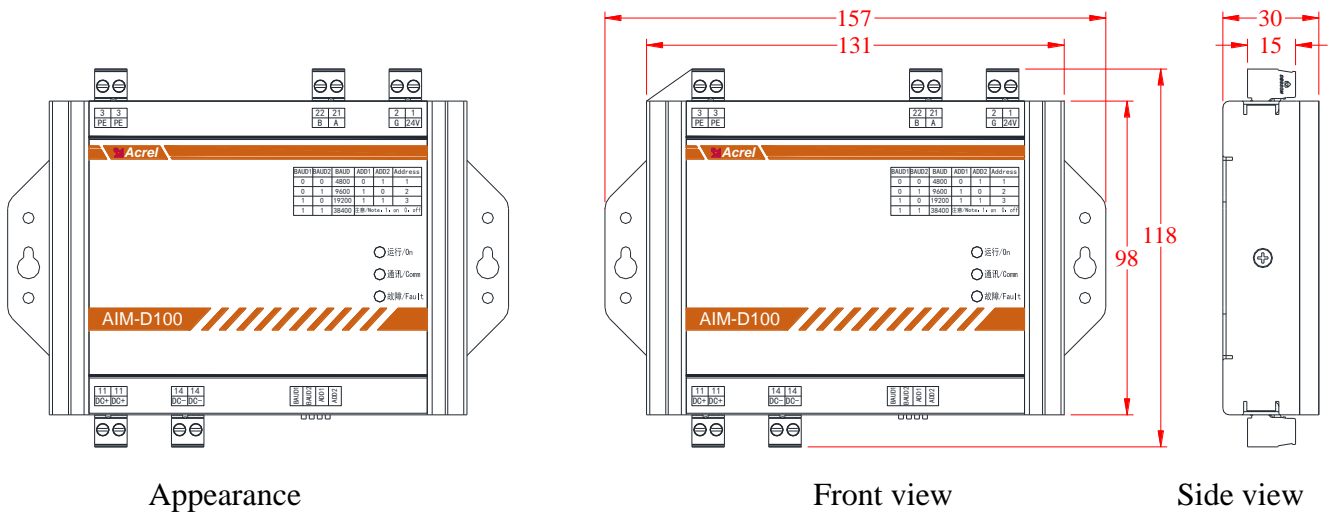

The overall dimensions of the AIM-D100-CAI DC Insulation Monitor are shown in the figure below. (Unit: mm)

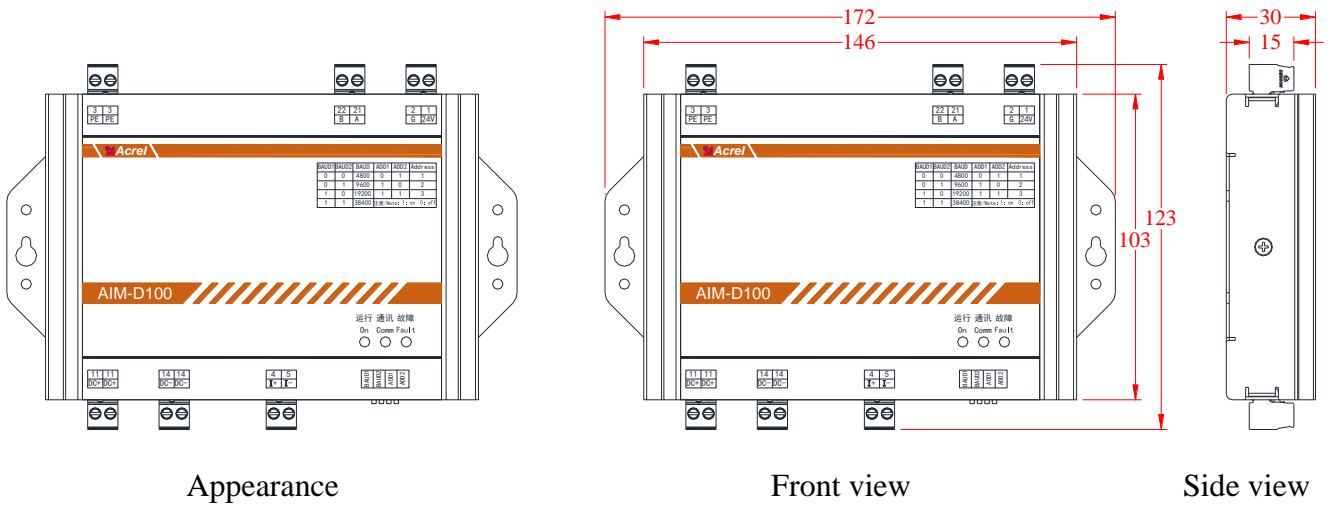

5.2 Installation

The AIM-D100-CA and CAI DC Insulation Monitors can be mounted in two ways. The mounting dimensions are shown below. (Unit: mm)

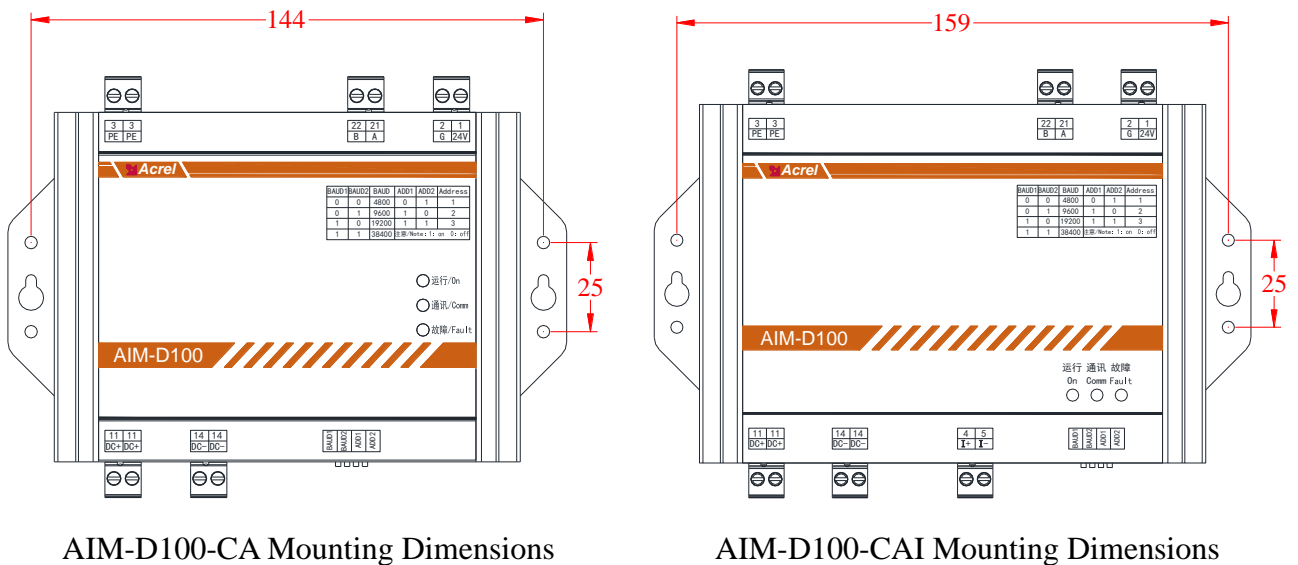

First installation method: wall-mounted installation. When installing the product, use the two M3 self-tapping screws (or other screws) provided with the product to pass through the mounting holes on both sides of the instrument and fix it to the bracket in the cabinet or the galvanized metal plate.

Second installation method: guide rail installation. When installing the product, first clamp the plastic stent that comes with the product on the guide rail. Align the mounting holes on both sides of the device with the plastic stent mounting holes. Use the 4 included M3 self-tapping screws to align the mounting holes and tighten them. The guide rail installation is as follows as shown in the below.

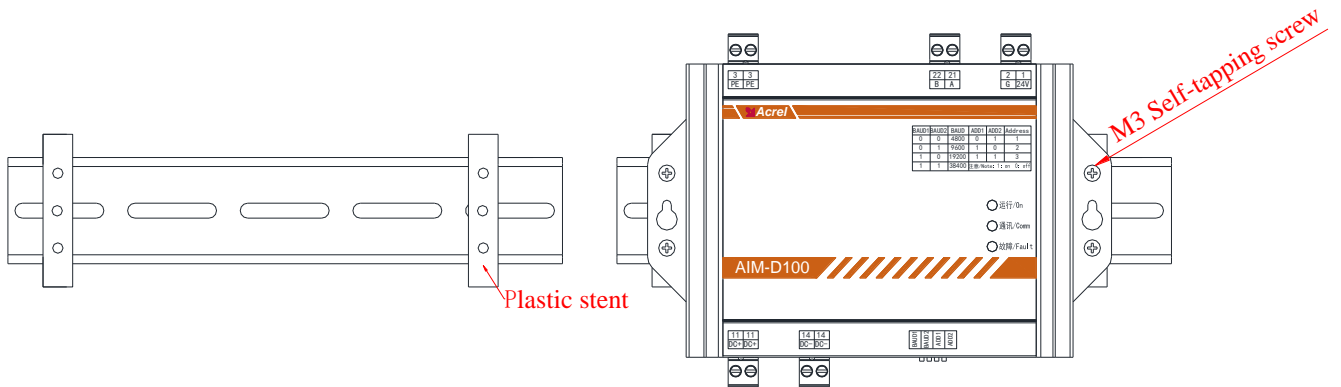

5.3 Wiring

AIM-D100-CA DC Insulation Monitor product wiring terminals are shown below:

1	2
24V	G

Power

3	3
PE	PE

Ground

11	11
DC+	DC+

Positive

14	14
DC-	DC-

Negative

21	22
A	B

RS485

AIM-D100-CAI DC Insulation Monitor product wiring terminals are shown below:

1	2
24V	G

Power

3	3
PE	PE

Ground

4	5
I+	I-

Current

11	11
DC+	DC+

Positive

14	14
DC-	DC-

Negative

21	22
A	B

RS485

Description:

Terminal 1 and 2: Connect to DC 24V power supply;

Terminal 3: Connect to the on-site grounding bar;

Terminals 4 and 5: Connect with current shunt;

Terminal 11: Connect to the positive pole of the DC system;

Terminal 14: Connect to the negative pole of the DC system;

Terminal 21 and 22: RS485 interface.

Wiring Specification:

For auxiliary power supply, functional grounding, and DC system positive and negative wiring, current shunt wiring, 1.5mm² multi-core copper wires can be used. RS485 communication wiring can use 0.75~1.5mm² shielded twisted pair.

5.4 Wiring Diagram

The AIM-D100-CA DC Insulation Monitor is wired as shown in the following schematic when monitoring the DC system:

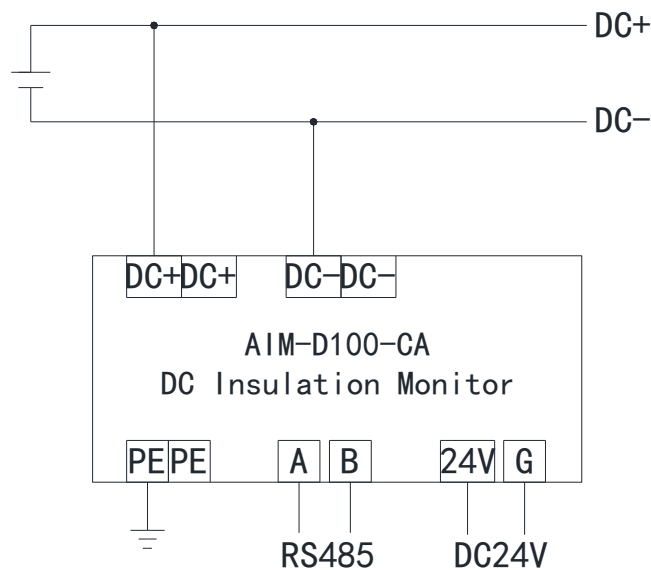

The AIM-D100-CAI DC Insulation Monitor is wired as shown in the following schematic when monitoring the DC system:

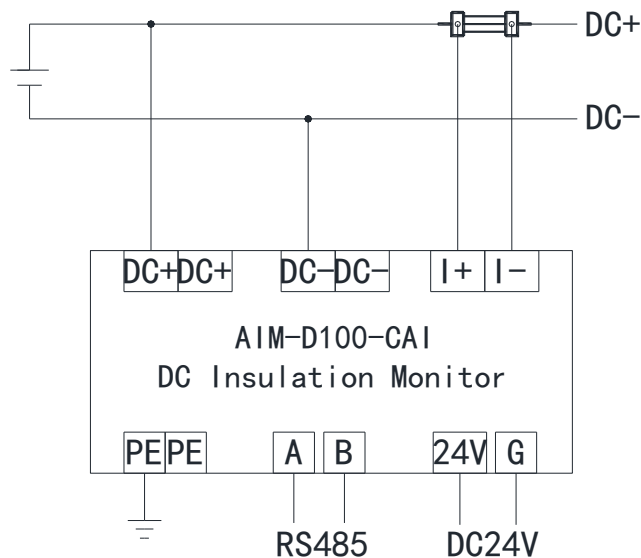

5.5 Attention

1) When designing and installing insulation monitors, it should be noted that only one insulation monitor can be installed in a system. If multiple insulation monitors are installed in different locations of the same system, a control strategy should be used for insulation resistance monitoring.

2) The insulation monitor can be installed in the distribution box, and the installation location is free of dripping water, corrosive chemical gases, and sedimentation substances.

3) When wiring the insulation monitor, you should strictly follow the wiring diagram. It is best to use a pin socket connector for crimping, then insert the instrument terminal and tighten the screws to avoid abnormal operation of the instrument due to poor contact.

4) The insulation monitor should be reliably connected to the DC system being monitored to ensure the effectiveness of insulation monitoring.

5) Non-professionals are strictly prohibited from opening the product casing without authorization to avoid affecting product functions.

6 Programming and Usage

6.1 Panel Description

The AIM-D100-CA panel description is shown below:

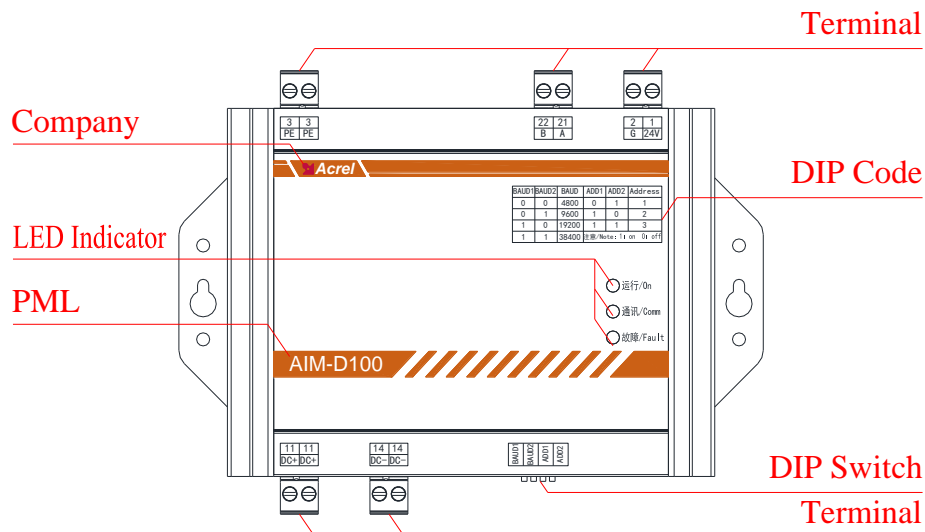

The AIM-D100-CAI panel description is shown below:

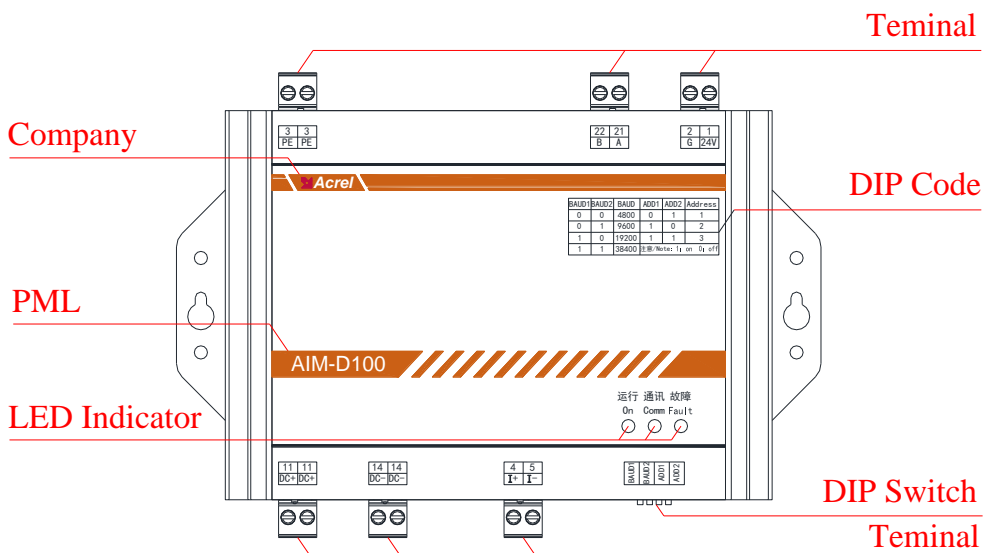

6.2 LED Indicator Instructions

Indicator	Function Description
On	When the instrument is running normally, the indicator light flashes with a flashing frequency of approximately once per second.
Comm	When there is no data communication, the indicator light is off. When there is data communication, the indicator light flashes.

Fault	The indicator light flashes when an insulation fault occurs and is always on when an insulation fault occurs.
-------	---

6.3 DIP Switch Description

AIM-D100-CA series Insulation Monitor is equipped with a 4-digit dipswitch at the lower row of terminals, and the functions corresponding to each set of dial codes are shown in the table below:

BAUD1	BAUD2	Baud rate	ADD1	ADD2	Address
0	0	4800	0	0	---
0	1	9600	0	1	1
1	0	19200	1	0	2
1	1	38400	1	1	3
Notes: 1: on 0: off					

The combination of BAUD1 and BAUD2 DIP switch: used to set the baud rate of RS485 communication. The factory default value is 10.

The combination of ADD1~ADD2 DIP switch: used to set the address of the instrument's RS485 communication. the default is 01.

7 Communication Instruction

7.1 Communication Protocol

The RS485 interface of the instrument adopts the Modbus-RTU communication protocol. The protocol defines the address, function code, data, check code, etc. in detail, which is a necessary content to complete the data exchange between the host and the slave.

7.1.1 Transmission method

Information transmission is asynchronous and in bytes. The communication information transmitted between the host and the slave is in an 11-bit format, including 1 start bit, 8 data bits (the smallest significant bit is sent first), and no Parity bit, 1 stop bit (N-8-1).

7.1.2 Information frame format

Address Code	Function Code	Data Zone	CRC check code
1 Byte	1 Byte	n Byte	2 Byte

Address code: The device address code is at the beginning of the data frame and consists of one byte (8-bit binary code), ranging from 0 to 255 in decimal. The device can set the address to 1 to 247. These bits identify the address of the user-specified end device that will receive data from the connected host. The address of each terminal device must be unique, and only the addressed terminal will respond to a query containing this address. When the terminal sends back a response, the slave address data in the response tells the host which terminal it is communicating with.

Function code: The function code indicates what function the addressed terminal performs.

Function Code	Definition	Explanation
03H/04H	Read data register	Get the current binary value of one or more registers
06H	Preset single registers	Set binary values to single registers
10H	Preset multiple registers	Set binary values to a series of multiple registers

Data zone: The data area contains the data required by the terminal to perform specific functions or the data collected when the terminal responds to queries. The content of these data may be numerical values, reference addresses or setting values. For example: the function code tells the terminal to read a register, and the data zone needs to indicate which register to start from and how much data to read. The embedded address and data vary according to the type and content between slaves. .

CRC check code: The error check (CRC) field occupies two bytes and contains a 16-bit binary value. The CRC value is calculated by the transmitting device and then appended to the data frame. The receiving device recalculates the CRC value when receiving the data and then compares it with the value in the received CRC field. If the two values are not equal, it occurs. mistake.

7.2 Function Code Introduction

7.2.1 Function code 03H or 04H: read register

This function allows users to obtain data and system parameters collected and recorded by the device. There is no limit to the number of data requested by the host at one time, but it cannot exceed the defined address range.

The following example reads a device value of 00 08H from the slave machine with address 01.

Host send		Sent information	Slave return		Returned information
Address code		01H	Address code		01H
Function code		03H	Function code		03H
Starting address	High byte	00H	Byte count		02H
	Low byte	08H	Register data	High byte	00H
Register count	High byte	00H		Low byte	50H
	Low byte	01H	CRC check code	Low byte	B8H
CRC check code	Low byte	05H		High byte	78H
	High byte	C8H			

7.2.2 Function code 06 or 10H: write register

Function code 10H allows the user to change the contents of multiple registers. The time and date in the instrument can be written with this function code. The host can write up to multiple data at a time (not exceeding the length defined by the instrument itself).

The following example is to set the date and time of the slave machine with address 01 to Friday, December 01, 2009, 12:00.

Host send		Sent information
Address Code		01H
Function Code		10H
Starting address	High byte	00H
	Low byte	04H
Register count	High byte	00H
	Low byte	03H
Register count		06H
0004H Data to be written	High byte	09H
	Low byte	0CH
0005H Data to be written	High byte	01H
	Low byte	05H
0006H Data to be written	High byte	0CH
	Low byte	00H
CRC check code	Low byte	A3H
	High byte	30H

Slave return		Returned information
Address Code		01H
Function code		10H
Starting address	High byte	00H
	Low byte	04H
Register count	High byte	00H
	Low byte	03H
CRC check code	Low byte	C1H
	High byte	C9H

Note: The above data is for reference only. Please refer to the address table for register definitions.

7.3 Register Address Table

No.	Address	Parameter	Read /Write	Value range	Data Types
0	00H	Reserved	R		UINT16
1	01H	Communication address	R	1~63 (default 1)	UINT16
2	02H	Baud rate	R	0~3: 4800, 9600, 19200, 38400 (Unit: bps) (default 1)	UINT16
3~11	03H~0BH	Reserved	R		UINT16*9
12	0CH	Software number	R		UINT16
13	0DH	Software version	R		UINT16
14~31	0EH~1FH	Reserved	R		UINT16*18
32	20H	Fault type	R	bit15: 1 DC+ and DC- connected reversely; 0 is normal bit14~bit6: Reserved bit5: 1 negative pole insulation fault warning; 0 is normal bit5: 1 negative pole insulation fault	UINT16

				alarm; 0 is normal bit3:1 positive pole insulation fault warning; 0 is normal bit2:1 positive pole insulation fault alarm; 0 is normal bit1~bit0: Reserved 00 18 means 0000 0000 0001 1000	
33	21H	Positive pole insulation resistance	R	Unit: k Ω ; Ratio is 1 For example, 10000, the resistance is 10M Ω	UINT16
34	22H	Negative pole insulation resistance	R		UINT16
35	23H	Positive pole voltage to ground	R	Unit: V; Ratio is 0.1 For example, 4567, the voltage is 4567*0.1=456.7V	UINT16
36	24H	Negative pole voltage to ground	R		UINT16
37	25H	System voltage	R		UINT16
38	26H	System current	R	Unit: A; Ratio is 0.01 For example, 2500 (mV), the value of current shunt is 4000, the current is 2500*0.01*4000=100000mA=100A	UINT16
39~51	27H~33H	Reserved	R		UINT16*13
52	34H	Insulation alarm switch	R/W	0xFEFE is on (default is on) 0xEF EF is off	UINT16
53	35H	Positive pole insulation resistance fault warning value	R/W	10~10000k Ω (default 100)	UINT16
54	36H	Positive pole insulation resistance fault alarm value	R/W	10~10000k Ω (default 50)	UINT16
55	37H	Negative pole insulation resistance fault warning value	R/W	10~10000k Ω (default 100)	UINT16
56	38H	Negative pole insulation resistance fault alarm value	R/W	10~10000k Ω (default 50)	UINT16
57~62	39H~3EH	Reserved	R		UINT16*6
63	3FH	Insulation monitoring speed	R	0:500ms/cycle; 1:1000ms/cycle	UINT16
64	40H	Reserved	R		UINT16
65	41H	Delay time of insulation monitoring capacitor	R/W	0~60000ms (default 0)	UINT16

7.4 Register Operation Description

7.4.1 Trigger Insulation Monitoring

0x20H~0x24H are special registers. Using the 0x03H or 0x04H command to read any of these registers will trigger an insulation monitoring cycle. Repeated readings within the insulation monitoring cycle are invalid. After the insulation monitoring cycle ends, the 0x03H command or 0x04H command that triggered the cycle will be returned. response.

7.4.2 Insulation Monitoring Speed

0x3FH is the insulation monitoring resistance time, and the insulation monitoring period can be set to 500ms or 1000ms. The accuracy of 500ms is slightly worse.

7.4.3 Delay Time of Insulation Monitoring Capacitor

0x41H is the insulation monitoring capacitance time. When the system capacitance is $>5\mu\text{F}$, the insulation resistance monitoring has a long response time and the insulation monitoring accuracy deteriorates. You can set the insulation monitoring capacitance time to 1000ms/10 μF and increase the monitoring time to stabilize the insulation measurement and eliminate the influence of capacitance.

7.5 Message Example

7.5.1 Read the insulation monitoring status

Host Send: 01 03 00 20 00 05 84 03

Slave Response: 01 03 0A 00 18 00 64 00 0A 11 94 01 C2 F7 A0

Data Analysis: 00 18 represents the fault type, the binary system is 0000 0000 0001 1000, the fault is positive insulation fault warning, negative insulation fault alarm; 00 64 represents the positive pole to ground insulation resistance, 100k Ω ; 00 0A represents the negative pole to ground insulation resistance, 10k Ω ; 11 94 represents the positive electrode to ground voltage, 4540/10 = 454.0V; 01 C2 represents the negative electrode to ground voltage, 450/10 = 45.0V.

7.5.2 Read the system voltage status

Host Send: 01 03 00 25 00 01 95 C1

Slave Response: 01 03 02 00 9A 38 2F

Data Analysis: 00 9A represents the system voltage, 154/10 = 15.4V.

7.5.3 Set Alarm Parameters

The alarm switch is turned on by default, the positive and negative insulation fault warning values default to 100k Ω , and the positive and negative insulation fault alarm values default to 50k Ω . No changes are required without special requirements. If you need to change, please refer to the following example.

1) Turn on the alarm switch

Host Send: 01 06 00 34 FE FE 09 E4

Slave Response: 01 06 00 34 FE FE 09 E4

2) Turn off the alarm switch

Host Send: 01 06 00 34 EF EF C5 B8

Slave Response: 01 06 00 34 EF EF C5 B8

3) Alarm threshold setting

Host send: `01 10 00 35 00 04 08 00 64 00 32 00 64 00 32 26 3E`

Slave response: `01 10 00 35 00 04 D1 C4`

Data analysis: 00 64 means setting the positive insulation fault alarm value to 100k Ω ; 00 32 means setting the positive insulation fault alarm value to 50k Ω ; 00 64 means setting the negative insulation fault alarm value to 100k Ω ; 00 32 means setting the negative insulation fault alarm value to 50k Ω .

8 Application

Electric vehicle charging device generally consists of cabinet, several AC to DC charging modules, intelligent switching unit, measuring instrument, controller, contactor, charging gun and so on.



The following figure shows an example of the application of AIM-D100-CAI DC Insulation Monitor in an electric vehicle DC charging unit.

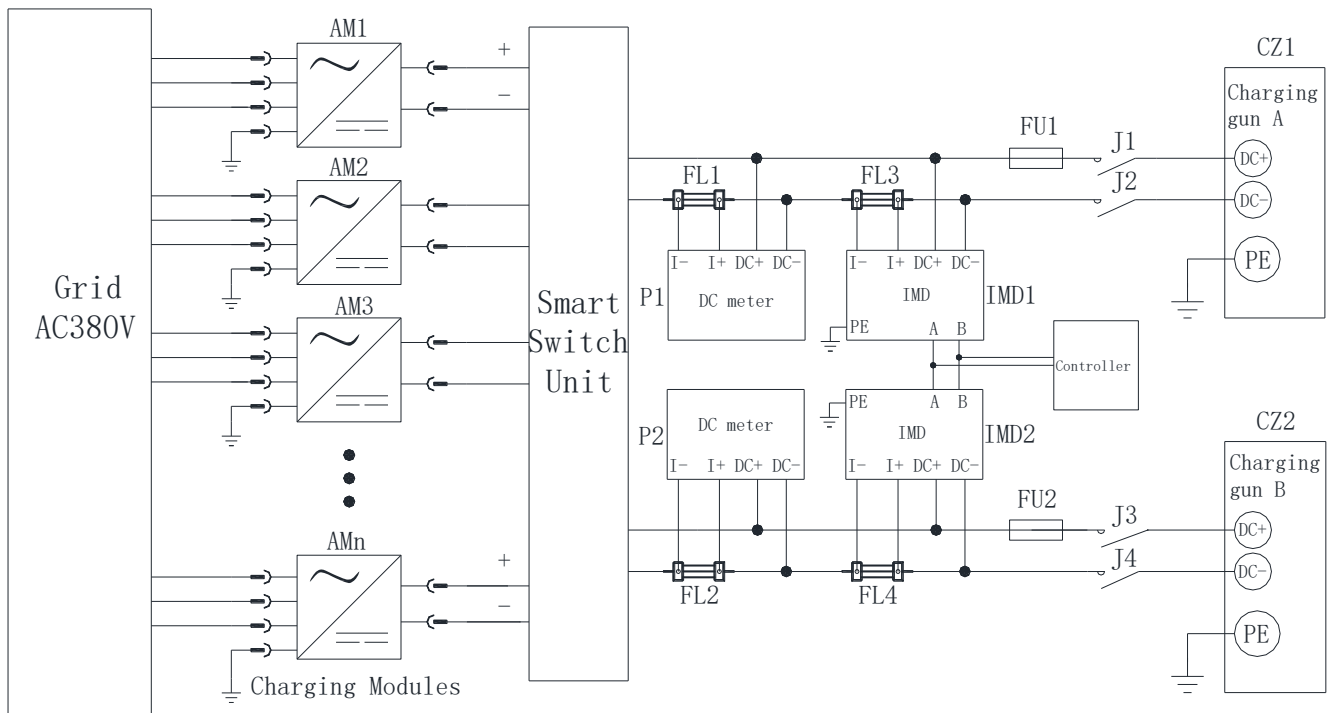

The example is a two-gun 120kW DC charging post. The intelligent switching unit controls the charging module, the DC meter measures the current, the insulation monitor measures the insulation voltage, the insulation resistance, and the insulation monitoring is controlled by the controller. When the charging pile is in use, when charging gun A or B is used alone, the controller issues a command to control the corresponding IMD1 or IMD2 insulation monitor for insulation monitoring; when charging guns A and B are used at the same time, the controller issues a command to control the IMD1 insulation monitor for insulation monitoring. If it is a single gun DC charging device, only one insulation monitor needs to be installed and controlled by the controller. Generally only one insulation monitor needs to be installed for a stand-alone DC system to avoid interference. The safety, stability and reliability of the DC charging system is guaranteed by the coordinated work of the controller and the insulation monitor.

Headquarters: Acrel Co., LTD.

Address: No.253 Yulv Road Jiading District, Shanghai, China

TEL.: 0086-21-69158338 0086-21-69156052 0086-21-59156392 0086-21-69156971

Fax: 0086-21-69158303

Web-site: www.acrel-electric.com

mail: ACREL008@vip.163.com

Postcode: 201801

Manufacturer: Jiangsu Acrel Electrical Manufacturing Co., LTD.

Address: No.5 Dongmeng Road, Dongmeng industrial Park, Nanzha Street, Jiangyin City, Jiangsu Province, China

TEL: 0086-510-86179966

Fax: 0086-510-86179975

Web-site: www.jsacrel.com

Postcode: 214405

E-mail: sales@email.acrel.cn